

3M™ Water Filtration Products

Cartridge Change-Out Instructions for Water Filtration System Model SW260-PLUS Replacement Cartridges: SW-CRF-60, SW-SR-60

SAFETY INFORMATION

WARNING

Read entire manual. Failure to follow all guides and rules could cause personal injury or property damage.

- Check with your local public works department for plumbing codes. You must follow their guidelines as you install the water filtration system.
- Your water filtration system will withstand up to 125 pounds per square inch (psi) water pressure. If your water supply pressure is higher than 80 psi, install a pressure reducing valve before installing the water filtration system.

To reduce the risk associated with choking:

- **Do not** allow children under 3 years of age to have access to small parts during the installation of this product.

To reduce the risk associated with the ingestion of contaminants:

- **Do not** use with water that is microbiologically unsafe or of unknown quality without adequate disinfection before or after the system. Systems certified for cyst reduction may be used on disinfected water that may contain filterable cysts.

NOTICE

To reduce the risk associated with property damage due to water leakage or flooding:

- **Read and follow** Use Instructions provided with the original system prior to use of this replacement cartridge.
- Change the disposable filter cartridge at the recommended interval; the disposable filter cartridge **MUST** be replaced every 12 months or sooner.
- Failure to replace the disposable filter cartridge at recommended intervals may lead to reduced filter performance and failure of the filter, causing property damage from water leakage or flooding.
- Protect from freezing, remove filter cartridge when temperatures are expected to drop below 40° F (4.4° C).
- **DO NOT** install systems in areas where ambient temperatures may go above 110° F (43.3° C).
- **DO NOT** install on hot water supply lines. The maximum operating water temperature of this filter system is 100°F (37.8°C).
- **DO NOT** install if water pressure exceeds 125 psi (862 kPa). If your water pressure exceeds 80 psi (552 kPa), you must install a pressure limiting valve. Contact a plumbing professional if you are uncertain how to check your water pressure.

IMPORTANT NOTES

- **The SW-CRF-60 and SW-SR-60 cartridges look very similar.** The cartridges are not interchangeable—forcing a cartridge into the incorrect location will cause damage.
- **Do not** use petroleum jelly.
- The clicking sound indicates that the cartridge is properly engaged.
- Top surface of the cartridge will become flush with the bottom of the plate when fully engaged.

Created for:



Cartridge Change-Out Instructions

for Water Filtration System Model SW260-PLUS

Replacement Cartridges: SW-CRF-60, SW-SR-60

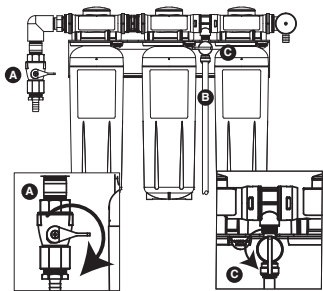

STEP ONE:

System Preparation

- A) Rotate shut-off valve on manifold to “OFF” position.
- B) Install plastic tubing provided into the vent valve on manifold. Direct tubing to drain.
- C) Open vent valve to depressurize system.

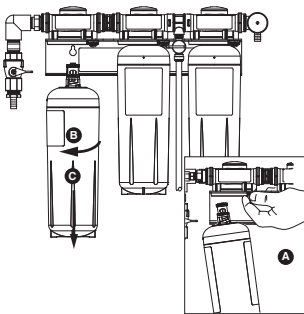

STEP TWO:

Cartridge Removal for SW-CRF-60 & SW-SR-60 Cartridges

- A) Push yellow tab on the filter retainer plate back and hold.
- B) Grasp cartridge securely and turn used cartridge to the left.
- C) Gently pull cartridge straight down and discard.

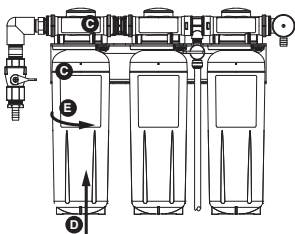

STEP THREE:

Cartridge Replacement for SW-CRF-60 & SW-SR-60 Cartridges

- A) Remove sanitary cap from new cartridge.
- B) Apply water to the o-rings on the cartridge.
- C) Match both Color of Label and Model # on cartridge label with Color and Model # on manifold.
- D) Align the tabs of the cartridge with the slots in the grey retaining plate and insert the cartridge into the manifold.
- E) Turn cartridge to the right until a clicking sound is heard. Repeat for the other cartridges.

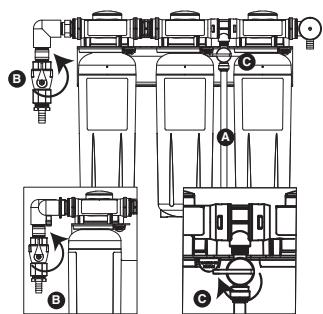

STEP FOUR:

Flush System

- A) Direct plastic tubing in vent valve to drain.
- B) Rotate shut-off valve on manifold to the “ON” position.
- C) Flush system in accordance with performance data sheet.
- D) Close flush valve. System is ready for service.

For program support services, call: 1.800.800.0657

Subway is a trademark of Doctor's Associates Inc.
 3M is a trademark of 3M Company.
 © 2018 3M Company. All rights reserved.
 34-8722-1501-6
 Please recycle. Printed in U.S.A.

3M Purification Inc.
 400 Research Parkway
 Meriden, CT 06450, USA
 Toll Free: 866.990.9785
 Worldwide: 203.237.5541
 Fax: 203.238.8701

www.3Mfoodservice.com • www.3Mpurification.com